

G-LINE 610

Automatic IN-LINE developing, de-greasing and drying system

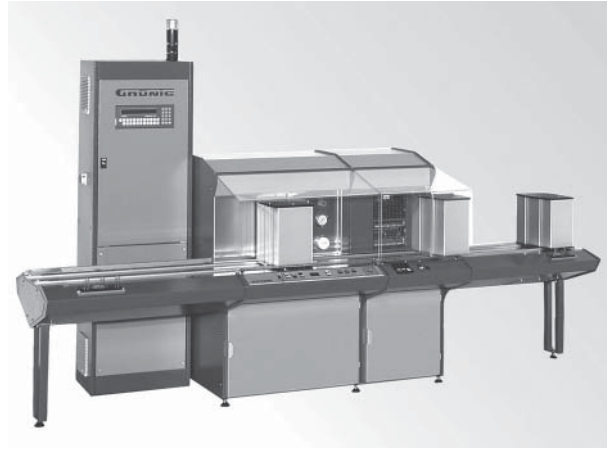

G-LINE 640

Automatic IN-LINE coating and drying system

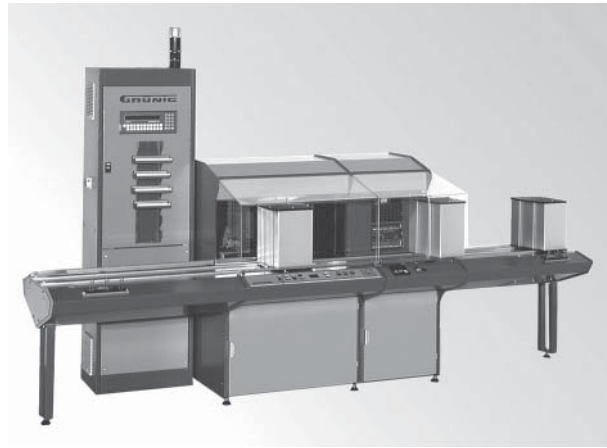

The G-LINE 600 allows producing small screens (CD) in top quality, with maximum speed and cost-efficiency, without operators

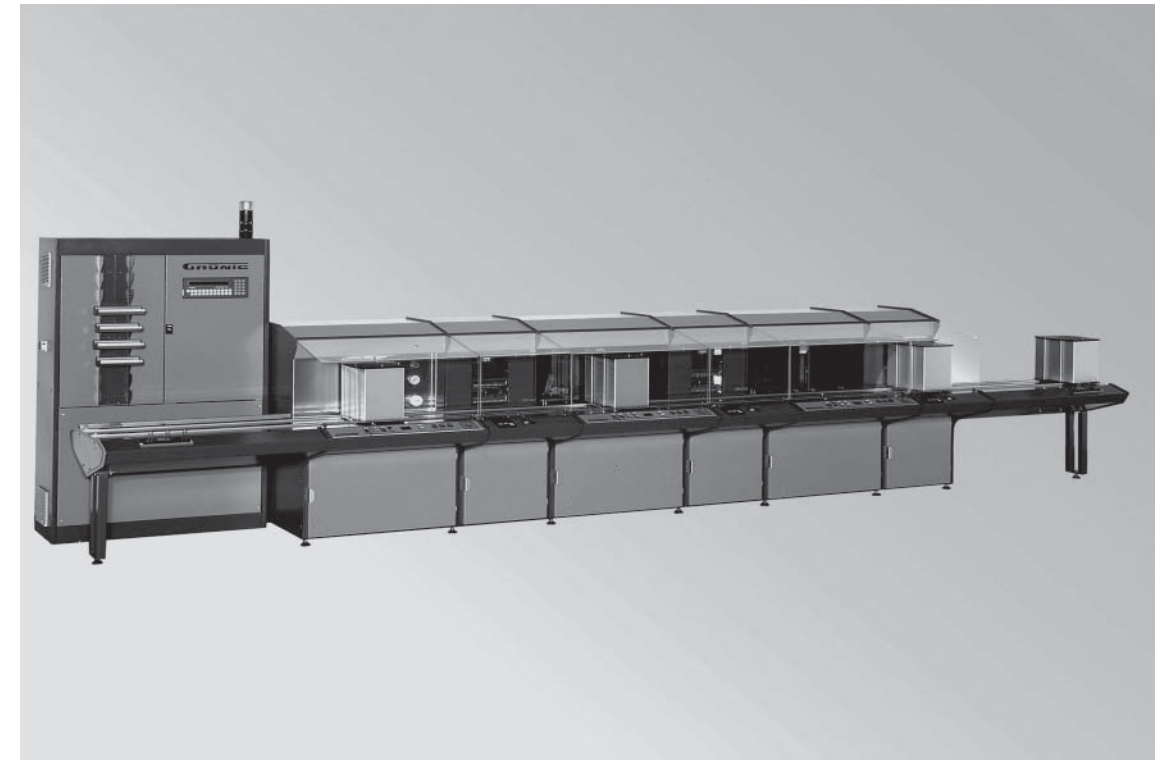

G-LINE 600

- G-LINE 600 Loading and unloading station
- G-LINE 610 Degreasing and developing station
- G-LINE 640 Basic coating station (PS and SS)
- G-LINE 641 Subsequent coating station (PS)
- G-LINE 650 Drying station

Possible Widths: 750/30" / 1000/39" / 1250/49"

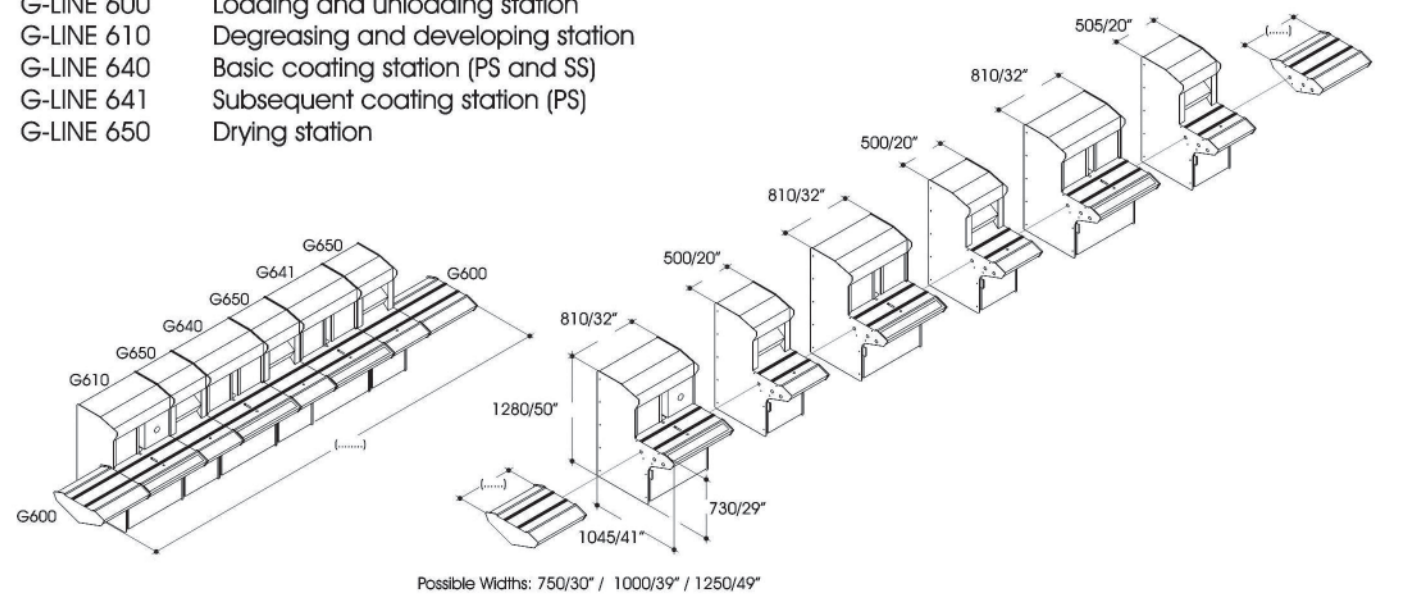

GRÜNIG

Grünig-Interscreen AG
 Ringgenmatt 14
 CH-3150 Schwarzenburg
 Switzerland

Phone +41 31 734 2600
 Fax +41 31 734 2601
www.grunig.ch
mail@grunig.ch



The machine answers the requirements of the EU guidelines for machinery (CE-conformity).
 Technical data subject to change without notice
 May 07

All measurements in mm/inches

G-LINE 600

Fully automatic production line for small printing screens (CDs)

Recapitulation of the essential features:

- Fully automatic modular and extensible production line for developing, degreasing, coating and drying small screens, in guaranteed reproducible manufacturing quality.
- Inline manufacturing with modular units which can be individually assembled from the left to the right, according to the requirements.
- No operating staff required. Just place the magazine onto the loading station, insert the coding plate and, at the end of the automatic process, remove the magazine from the unloading station.
- When loading the magazines, the coloured coding plates are inserted into the magazine according to the needs. These different coding plates determine the respective treatment procedure for the entire magazine.
- Production capacity ~50-70 screen frames per hour for automatic degreasing, developing, coating and drying.
- If the reproducible quality is combined with an appropriate direct emulsion, the use of capillary film is no longer necessary. Most of the direct emulsions customary in trade can be used; their share of non-volatile matter should be as high as possible.
- A layer build-up of 3-6 μ on top of the mesh (print side), with a Rz-value of < 6 is possible in reproducible quality.
- The high degree of automation and the use of direct emulsion instead of capillary film allows to achieve a considerable reduction of the manufacturing costs.
- All the modules can also be supplied as individual "island" solutions, e.g. only the coating and drying units (G-LINE 640). A subsequent installation of additional modules is always possible at a later date.
- Control concept designed on the basis of state-of-the-art technology with centralized microprocessor control and decentralized intelligent terminal modules which are controlled via a field bus.

Module G-LINE 600 loading and unloading station

- The length of the loading and unloading station can be selected among the following versions:
 - Length 750 mm: accomodating 3 magazines
 - Length 1000 mm: accomodating 4 magazines
 - Length 1250 mm: accomodating 5 magazines
- Magazine transport by means of chain drive system from the left to the right side
- Checking of the unloading station if the available space is fully occupied by magazines; with automatic stopping of the machine and message to the operator
- Control cabinet with trough shelf and operator console
- MMI clear text display supplying information with regard to the machine status, the counter totals, error messages, maintenance instructions.



Module G-LINE 610 Degreasing and developing station

- All the elements entering in contact with water are made of special steel V2A WST 1.4301
- Mixing battery hot/cold water with thermostat
- Water pressure regulator, adjustable pressure
- Water nozzles on both sides with conduit pressure via mixing battery
- Chemical nozzles on both sides with double membrane pump
- Blowing-out of the wet screens with ventilator and air nozzles
- Work processes degreasing (Option C)
- Each one with 5 different programs for developing and degreasing, with various parameters (speed, soaking time and washing moves)

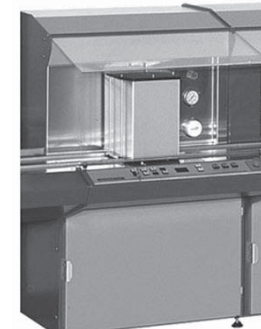

Module G-LINE 641 Subsequent coating station

- Module for layer build-up on one side (print side)
- Patented Grünig coating head
- All the other functions are the same as for the G-LINE 640 module



Modul G-LINE 650 Drying station

- Heating chamber made of special steel V2A WST 1.4301
- Temperature programmable by means of a processor regulator
- The heating time is adjustable
- Simultaneous drying of all the screens using feeder magazines (max. feeder capacity: 10 screens)
- Suction of fresh air by means of an inlet slide blade with filter
- Exhaust air with circulation slide blade
- A manual drying of one single magazine is possible

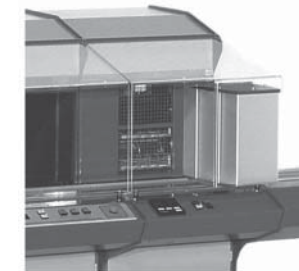

Module G-LINE 640 Basic coating station

- Module for basic coating on both sides
- Patented Grünig coating heads
- Trough cleaning with wiper lips on both sides
- Monitoring of the layer build-up with automatic refilling of the troughs
- Automatic detection of mesh rupture
- Static discharge of the mesh/screen (ANTISTATIK)
- 5 different programs for coating, with various parameters (speed, flow time and coating moves)
- Complete set of troughs G-COAT 401 included

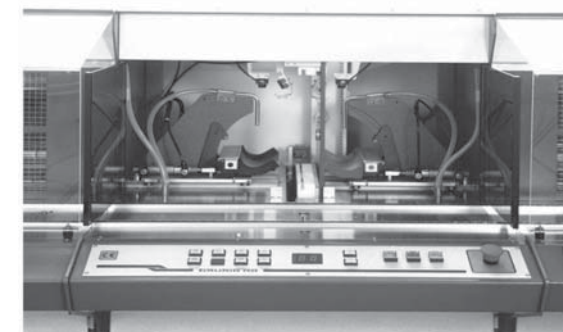

Module G-LINE 690 Feeder magazine

- One magazine offers enough space for max. 10 screens
- The feeder magazines are stackable
- The weight of a full magazine is max. 10 kg
- The magazines can be coded for various process sequences

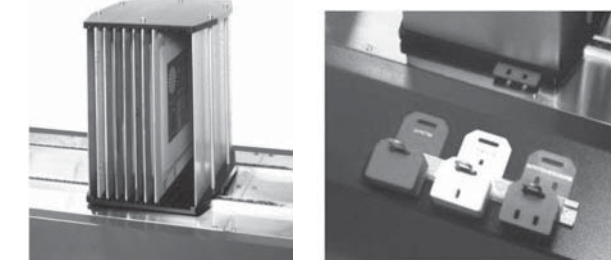

Screen frame size	CD-Screen frame size	mm	254 x 275 x 3-5	Compressed air	Connection rating	BAR7psi	6/87
		inch	10" x 11" x 0.1"-0.2"				
		mm	305 x 305 x 3-5	Exhaust Air	G-LINE 610	Exhaust air quantity	m3/h
		inch	12" x 12" x 0.1"-0.2"				
	mm	310 x 310 x 3-5	G-LINE 650	Exhaust air quantity	m3/h	200	
	inch	12" x 12" x 0.1"-0.2"					
Other formats possible upon inquiry							
Options	G-LINE 600	Loading and unloading station					
	G-LINE 610	Degreasing and developing station					
	G-LINE 640	Basic coating station					
	G-LINE 641	Subsequent coating station					
	G-LINE 650	Drying station					
	G-LINE 690	Magazine for 10 screens					
Dimensions (per module with drying)	Total width	mm/inch	1310/52"	Permanent sound pressure level			
	Total height	mm/inch	1280/50"		dB (A) < 70		
	Total depth	mm/inch	1045/41"				
Energy supply	3 x 400 V / 3 x 220 V / 50-60 Hz			Programs	G-LINE 610	5 sub-programs Developing	
						5 sub-programs Degreasing	
						5 sub-programs Basic coating	
						5 sub-programs Subsequent coating	
				G-LINE 650	1 sub-program Drying		
				Speed	Coating	min. 10 mm/sec.	max. 99 mm/sec.
				Speed	Degreasing	min. 10 mm/sec.	max. 99 mm/sec.
				Speed	Developing	min. 10 mm/sec.	max. 99 mm/sec.

All measurements in mm/inches



The machine answers the requirements of the EU guidelines for machinery (CE-conformity).

Technical data subject to change without notice

May 07